



MBCE-110/230UV Flame Sensor Module



DESCRIPTION

The MBCE-110/230UV modules provide visual indication and electrical outputs that signal the user regarding flame presence in a combustion chamber. The module uses Fireye UV scanners to sense flame presence independently or as components in a burner management system. Many operational characteristics are provided including:

- CE certified
- Self-contained: 110 VAC, 50/60 Hz: MBCE-110UV-1, MBCE-110UV-2
MBCE-110UV-3, MBCE-110UV-4
230 VAC, 50/60 Hz: MBCE-230UV-1, MBCE-230UV-3
- UV scanner compatible*
- Flame ON/OFF LED indicator
- 4-20mA output permits direct reading of flame signal strength
- Uses CE certified 11-pin relay base
- Panel surface or DIN-rail mounting
- Flame pull-in threshold adjustment

The module provides a cost effective method of monitoring flames using UV sensing. The MBCE-UV is intended for non-permanent operation (burner must be recycled at least once every 24 hours). The MBCE-UV is ideally suited for flame detection in natural gas applications; however, it can be used for flame detection in propane and light fuel oil applications.

Check with Fireye for more details by contacting your local distributor or by checking the Fireye home page at: www.fireye.com.

***NOTE:** When the MBCE-110/230UV modules are used, additional means must be furnished to provide those functions usually provided by flame safeguard control systems to meet local regulations (i.e.: safe start check, valve closure, starting and running interlocks, safety timings, etc.).*

*The MBCE-UV shall be powered continuously from a separate source other than the Burner control per EN 298. * see ordering information*



NOTICE: When Fireye products are combined with equipment manufactured by others and/or integrated into systems designed or manufactured by others, the Fireye warranty, as stated in its General Terms and Conditions of Sale, pertains only to the Fireye products and not to any other equipment or to the combined system or its overall performance.



ORDERING INFORMATION

PART NUMBER	DESCRIPTION	BULLETIN
Flame Sensor		
MBCE-110UV-1	Single channel module, 110 VAC 50/60 Hz, use with UV scanner, 1 sec. FFRT.	MBCE-1002
MBCE-110UV-2	Single channel module, 110 VAC 50/60 Hz, use with UV scanner, 2 sec. FFRT.	MBCE-1002
MBCE-110UV-3	Single channel module, 110 VAC 50/60 Hz, use with UV scanner, 3 sec. FFRT.	MBCE-1002
MBCE-110UV-4	Single channel module, 110 VAC 50/60 Hz, use with UV scanner, 4 sec. FFRT.	MBCE-1002
MBCE-230UV-1	Single channel module, 230 VAC 50/60 Hz, use with UV scanner, 1 sec. FFRT.	MBCE-1002
MBCE-230UV-3	Single channel module, 230 VAC 50/60 Hz, use with UV scanner, 3 sec. FFRT.	MBCE-1002
Wiring Base		
60-2886	Plug in wiring base, DIN rail or panel surface mount complete with retaining kit.	MBCE-1002
Mounting Rails		
60-2539-12	DIN style mounting rail, 12 inches, mounts up to 4 modules.	
60-2539-24	DIN style mounting rail, 24 inches, mounts up to 8 modules.	
60-2539-36	DIN style mounting rail, 36 inches, mounts up to 12 modules.	
UV Scanner		
UV90L-1	UV scanner, front and side viewing.	SC-108
UV5-1	UV scanner, front and side viewing.	SC-108
UV1AL-3	UV scanner, 1/2" NPT, 36" (915mm) shielded leads.	SC-108
UV1AL-6	UV scanner, 1/2" NPT, 72" (1830mm) shielded leads.	SC-108
4-742-1	Replacement tube for UV90L-1.	

PRODUCT SPECIFICATIONS

Supply Voltage:	MBCE-110UV - 110 VAC (+20%, -15%), 50/60 Hz (@ 0.02 Amp consumption) MBCE-230UV - 230 VAC (+10%, -15%), 50/60 Hz (@ 0.01 Amp consumption)
Flame Relay Output:	SPDT 1 Amp Resistive @ 110VAC, 1 Amp @ 30VDC SPDT 1 Amp Resistive @ 230VAC, 1 Amp @ 30VDC
Flame Failure Response Time:	1 or 3 seconds-depending on part number (-1, -3) for CE 1, 2, 3, or 4 seconds-depending on part number (-1, -2, -3, -4) for UL
Operating Temperature:	- 40° F to 150° F (- 40° C to 65° C)
Storage Temperature:	- 58° F to 185° F (- 50° C to 85° C)
Humidity:	85% RH (max), non-condensing.
Agency Approvals:	MBCE-110UV UL MBCE-230UV CE / EN298:2012
Shipping Weight:	1 lb (.5 Kg)
UV Scanner:	S1 = Terminal 4 S2 = Terminal 8 UV tube excitation Terminals 4 and 8, +300 VDC (max)
IP-Rating	IP-20
Test Jacks:	Standby/No flame 4mA Flame signal (Min) 5.5mA Flame signal (Max) 20mA



NOTICE: MBCE-UV module does not have any user serviceable parts. If the unit has a problem, return the unit to your local distributor, or contact Fireeye directly.

Adequate disconnect means and overload protection is required. A 1 amp external fuse is recommended on terminal 10 for over-current protection.

FIGURE 1. DIMENSIONS OF DIN RAILS, WIRING BASES AND FLAME SWITCH MODULES SHOWN IN INCHES (MM)

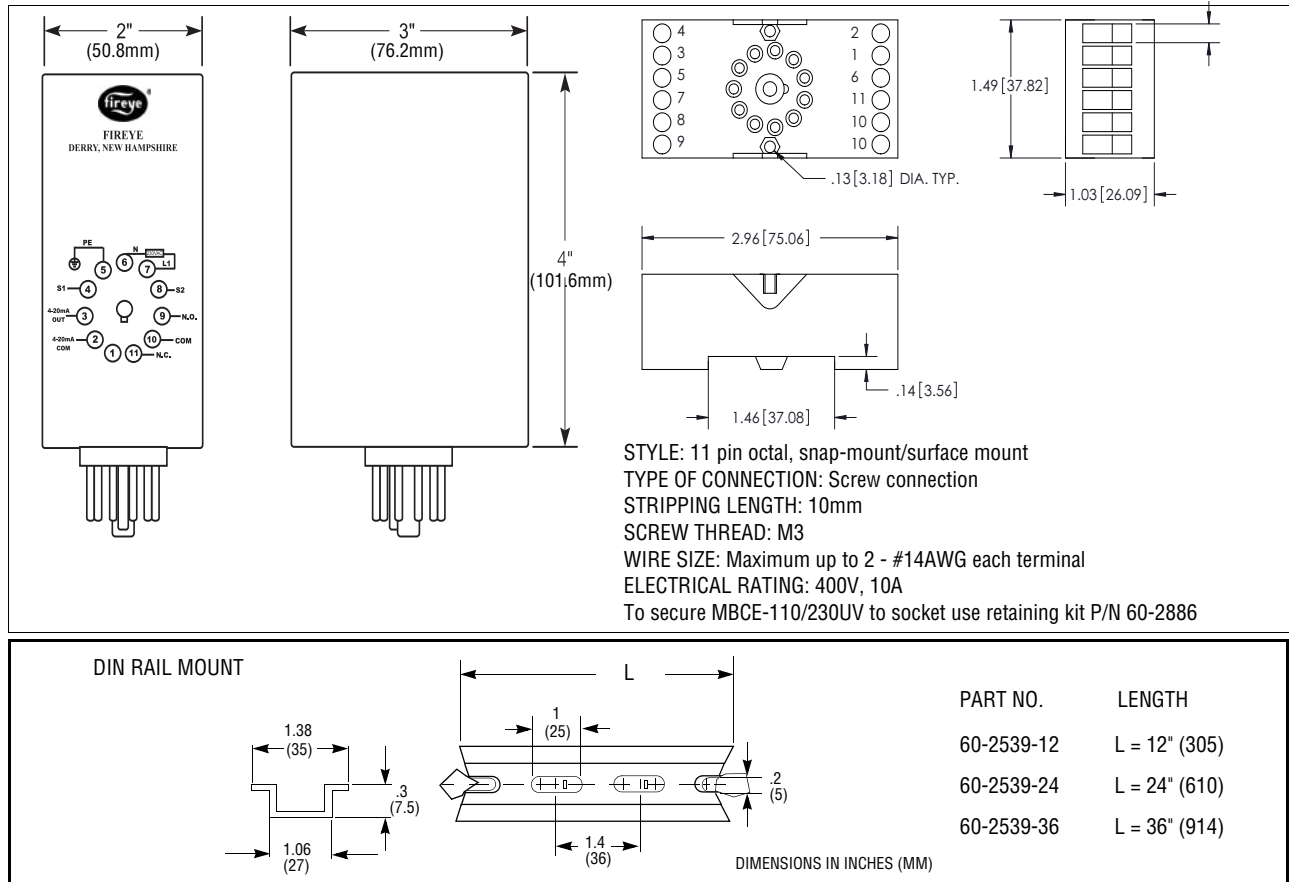

CERTIFICATION:

The MBCE-230UV-1 & MBCE-230UV-3 have been evaluated to EN 298:2012 by DIN DVGW, and meet the Gas Appliance Directive (2009/142/EC)

CE Certificate # CE-0085CR0115

DIN DVGW Certificate # NG-4131CR0016



NOTICE: The MBCE-UV is designed to be used with a compatible UV scanner in order to sense the flame activity in a combustion chamber. The MBCE-UV is not designed to replace a burner control system, and it cannot assume the responsibilities of a burner control system, including burner safe start check.

NOTICE: Consult national or local codes for proper selection of the MBCE-UV modules. Some codes require that the flame failure detection time should not be greater than 1 second.



WARNING: The equipment described in this manual is capable of causing property damage, severe injury, or death. It is the responsibility of the owner or operator to ensure that the equipment is installed, operated and commissioned in compliance with the requirements of all national and local legislation, which may prevail.

FLAME SCANNERS



CAUTION: The UV90L-1, UV1AL, and UV5-1 flame scanners are non-self checking UV sensors. Use these only on burners that cycle often (e.g.: a minimum of once every 24 hours) in order for the external safety checking circuit to be exercised.

INSTALLATION - UV SCANNERS

Where possible, obtain the burner manufacturer's instructions for mounting the UV scanner. This information is available for most standard burners. The UV scanner mounting must comply with the following general instructions:

1. Position the UV1AL, UV5, or UV90L scanner within 30 inches of the flame to be monitored.
2. Select a scanner location that remains within the ambient temperature limits of the UV Scanner. If cooling is required, use an insulating coupling (Fireeye #35-69 for UV1AL to reduce conducted heat).
3. The UV1AL Scanner is designed to seal off the sight pipe up to 1 PSI pressure. Higher furnace pressures must be sealed off. To seal off positive furnace pressure up to 100 PSI for UV1AL Scanner, install a quartz window coupling (#60-1257). Add cooling air to reduce the scanner sight pipe temperature.
4. Install the scanner on a standard NPT pipe (UV1AL) whose position is rigidly fixed. If the scanner mounting pipe sights through the refractory, do not extend it more than halfway through. Swivel flanges are available if desired (#60-302 for UV1AL) . The sight pipe must permit an unobstructed view of the pilot and/or main flame. Both pilot and main flames must completely cover the scanner field of view

FIGURE 1. AIMING YOUR SCANNER.

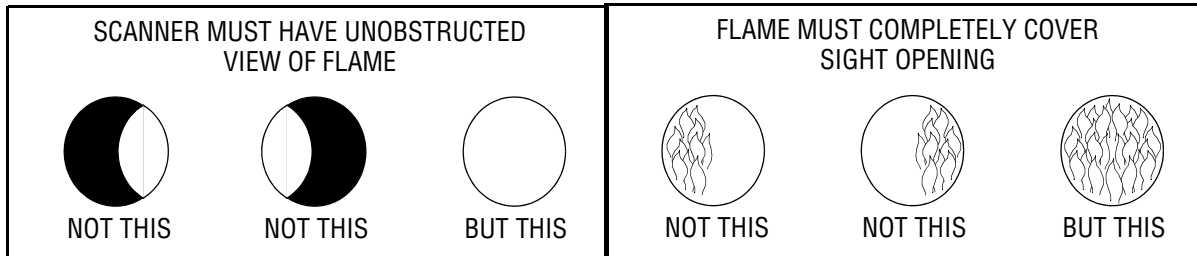

5. Smoke or unburned combustion gases absorb ultraviolet energy. On installations with negative pressure combustion chambers, a small hole drilled in the UV1AL sight pipe keeps the pipe clean and free from smoke. For positive pressure furnaces, provide clean air to pressurize the sight pipe, if necessary.
6. To increase scanner sensitivity with UV1AL, use a union with quartz lens (Fireeye #60-1290). This should facilitate the location of the scanner at twice the normal distance. Use 1/2" x 1 1/2" pipe nipple between UV1AL Scanner and the coupling.
7. Request the assistance of any Fireeye field office for recommendations of a proper scanner installation on a non-standard application.

FIGURE 2. TYPICAL SCANNER INSTALLATIONS

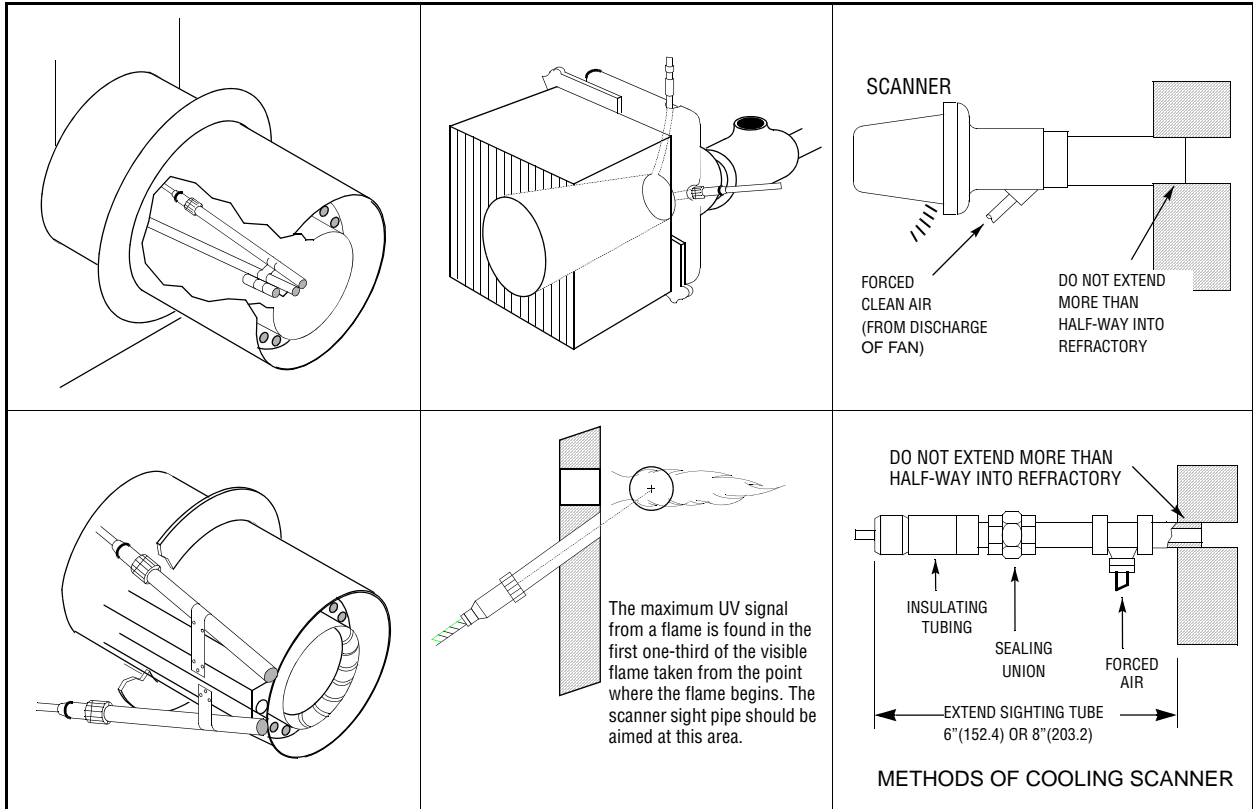

WIRING - UV SCANNERS

To connect the scanner to the control, the UV1AL Scanner is supplied with 36"(.9m) or 72" (1.8m) of cable. The UV5-1 scanner is supplied with an 80" (2m) cable. The UV90L-1 provides field wire-able terminal block.

If it is necessary to extend the scanner wiring, the following instructions apply:

Scanner wires should be installed in a separate conduit. The wires from several scanners may be installed in a common conduit.

1. Selection of Wire
 - a. Wiring: For extended scanner wiring up to 500 feet, and for shorter lengths to reduce signal loss, use a shielded wire (Belden 8254-RG62 coaxial cable, or equal) for each scanner wire of UV1AL. The ends of the shielding must be taped and not grounded.
 - b. Asbestos insulated wire should be avoided.
 - c. Multiconductor cable is not recommended without prior factory approval.
2. High voltage ignition wiring **should not** be installed in the same conduit with flame detector wires.



WARNING: Incorrect MBCE-UV scanner installation can result in the generation of a false flame signal, causing unburned fuel to collect in the combustion chamber. The result can be explosions, injuries and property damage. Be certain that the UV scanner detects only pilot and/or main flames.

3. Route scanner wiring a sufficient distance from ignition and other high voltage or high current wiring to avoid electrical interference. Interference from ground currents, nearby conductors, radio-frequency emitters (wireless devices), and inverter drives can induce false flame signals. In some applications shielded cables can help reduce interference with the shield connected to ground at the control end only. The wire type and its capacitance (picofarads or microfarads) to ground may cause low signal problems, so a grounded shield can decrease the signal due to the cable's internal capacitance. Multiple sensor leads run together without shielding may cause interference or "cross talk", so the shield or flexible armor must be grounded to prevent this situation.

THRESHOLD ADJUSTMENT

The MBCE-UV module is equipped with a flame pull-in threshold adjustment capability. This feature allows the user to dial in the appropriate flame signal threshold for the internal flame relay to engage. When set, the flame signal strength must be greater than the threshold before the MBCE-UV can signal "FLAME ON".

The adjustment can be made at the front faceplate potentiometer with the aid of a small flat blade screwdriver. A clockwise adjustment of the potentiometer decreases the flame pull-in threshold of the MBCE-UV module allowing the MBCE to pull-in at "small" flame conditions. Likewise, a counter-clockwise adjustment of the potentiometer increases the flame pull-in threshold of the MBCE-UV module allowing the MBCE to pull-in at "big" flame conditions. The 4-20mA output of the MBCE-UV module signals 5.5mA at the pull-in threshold.

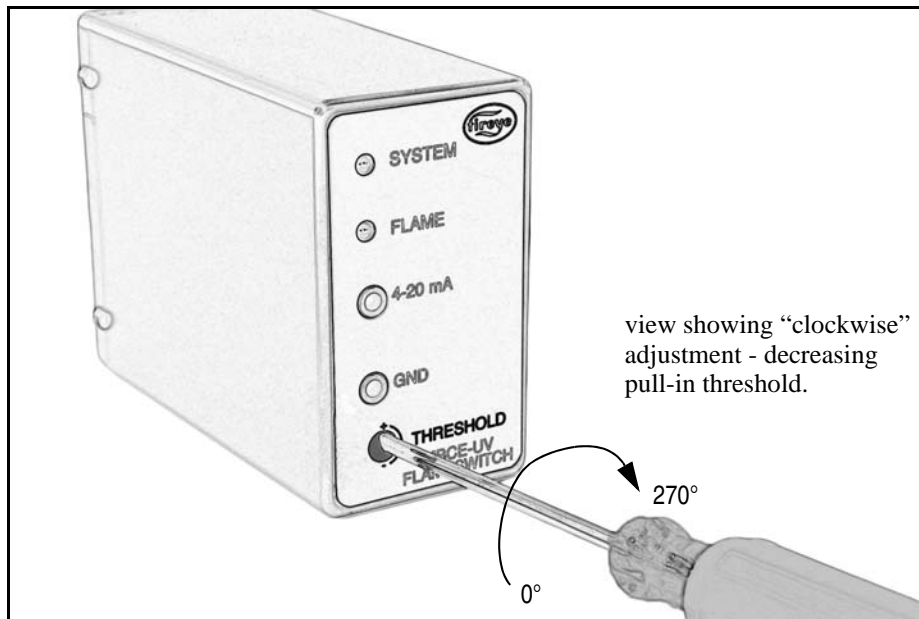

NOTICE



- Apply proper grounding technique when adjusting the threshold potentiometer
- The adjustment potentiometer is recessed about 3/8" from the surface. Do not over extend the screw driver into the product as this may damage the product.
- Ensure that the screw driver is centered on the adjustment slot to facilitate proper adjustment.
- Do not apply excessive force as only a minimum force is needed for adjustment.
- The overall rotational angle of adjustment is three quarter turn (270 degrees). Do not over extend.

INDICATION LEDS

The MBCE-UV Flameswitch contains two bi-color LEDs. These are used to provide flame status and alarm conditions. See the following table.

View the LEDs through the cutout located on the top side of the unit.

Table 1:

LED	COLOR	DEVICE STATUS
LED 1 (SYSTEM LED)	GREEN	SYSTEM OK
	BLINKING RED/ORANGE	SYSTEM FAULT
	SOLID RED/ORANGE	
LED 2 (FLAME LED)	SOLID GREEN	GOOD FLAME
	BLINKING GREEN	WEAK FLAME
	BLINKING RED/ORANGE	SYSTEM FAULT
	SOLID RED/ORANGE	
	OFF	FLAME OFF

NOTE: power cycling the unit should reset some system faults. If problem persists, please contact local distributor or factory.

FIGURE 2. FLAME SIGNAL STRENGTH vs. 4-20mA OUTPUT

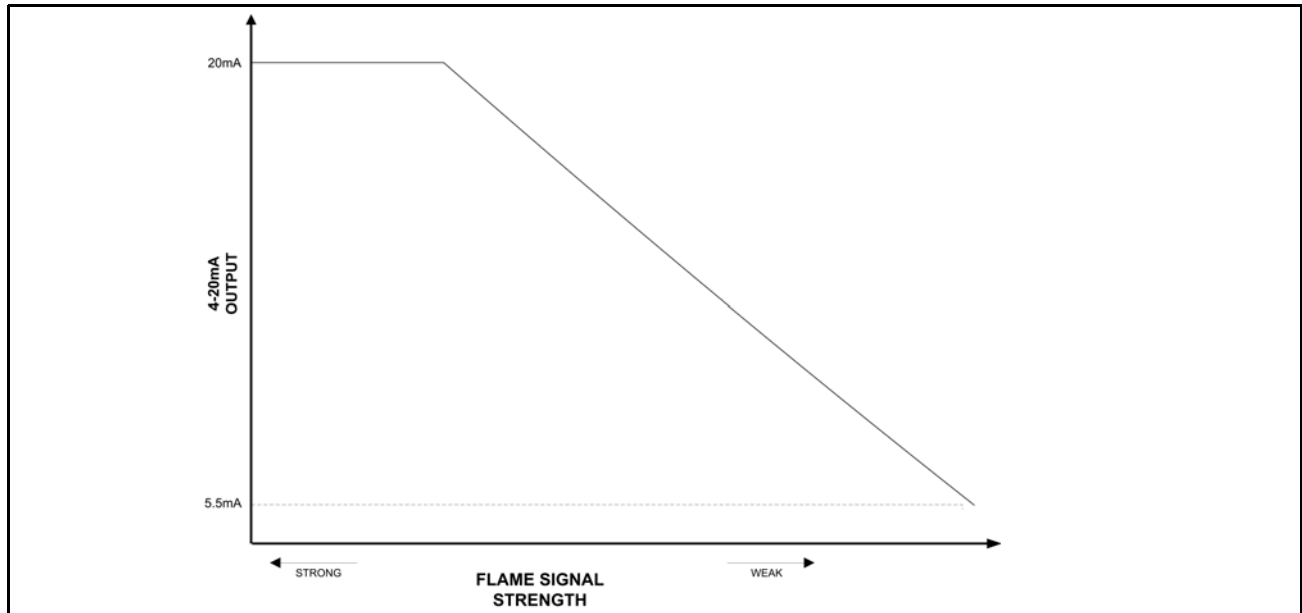



WIRING BASE PINOUT INFORMATION

The following table shows the wiring information and the ratings. To guarantee proper operation, the MBCE-UV module **MUST NOT** be operated above its maximum rating.

TERMINAL NO.	TERMINAL NAME	DESCRIPTION	DIRECTION	RATING
1	(11)	OPEN	UNUSED	N/A
2	(A1)	4-20mA COM	4-20mA COMMON	RETURN
3	(14)	4-20mA OUT	4-20mA OUTPUT	OUTPUT
4	(12)	S1	UV TUBE EXCITATION	OUTPUT
5	(22)	E	EARTH	EARTH GROUND
6	(21)	L2	NEUTRAL	INPUT
7	(24)	L1	LINE VOLTAGE SUPPLY	INPUT
8	(32)	S2	UV TUBE RETURN	
9	(34)	NO	FLAME RELAY NORMALLY OPEN (N.O.)	OUTPUT
10	(A2)	COM	FLAME RELAY COMMON	INPUT
11	(31)	NC	FLAME RELAY NORMALLY CLOSED (N.C.)	OUTPUT



NOTICE: The 4-20mA output on the faceplate/wiring base is not evaluated for its isolation from mains voltage and there is a risk of electrical shock under single fault conditions. Any connection to the 4-20mA current loops shall be insulated from other circuits, user accessibility, and/or earth by protective separation meeting the requirements of double or reinforced insulation (except, only basic is required for isolation from earth) according to DIN EN/UL 61010, DIN EN 50178, DIN EN/UL 60730-1 or DIN EN/UL 60950.

4-20mA measurements can be taken from the test jack connector located at the faceplate of the unit. Measurements can also be taken using the dedicated 4-20mA OUT & 4-20mA COM terminals located at the wiring base.



NOTICE: The 4-20mA return path is labeled "GND" on the faceplate. This is simply a local return path for the 4-20mA current and it **MUST NOT** be attached or referenced to earth ground or other forms of ground connection. Likewise, 4-20mA COM is the return path at the wiring base and **MUST NOT** be attached or referenced to earth ground or other forms of ground connection.

Only one 4-20mA loop device/PLC is allowed to be connected to the 4-20mA interface. The connection can be at the terminal or through the face plate. **DO NOT** connect loop devices to the terminals and face plate interface simultaneously.

FIGURE 3. TYPICAL APPLICATION - MBCE-110/230UV

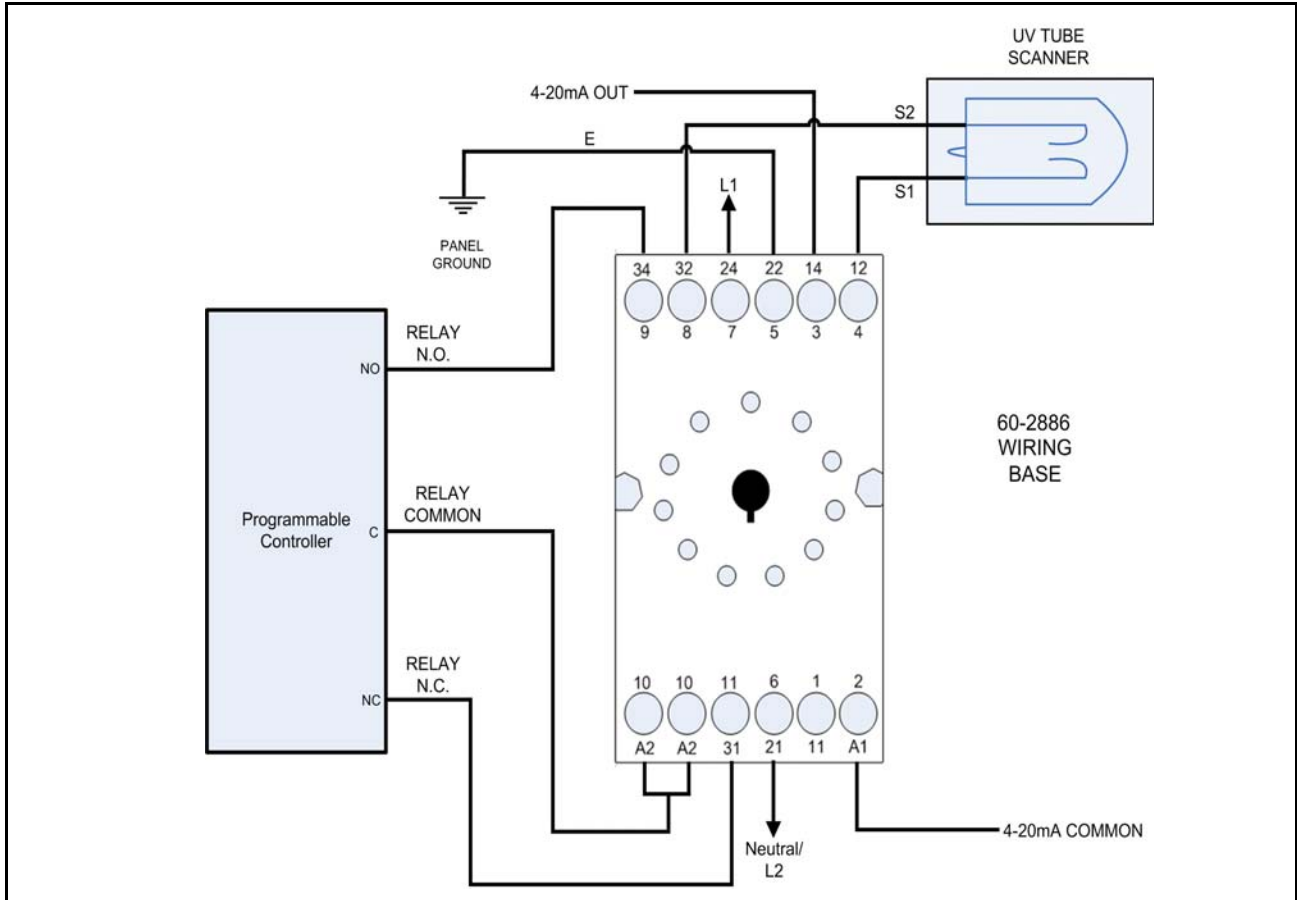

CAUTION: SPECIAL CONDITIONS OF USE

- 1 The equipment, wiring base, and its enclosure are considered hazardous live parts and shall be installed in compliance with the enclosure, mounting spacing and segregation requirements of the ultimate application to protect the user against electric shock and the equipment against ingress of water and dust.
2. Line voltage and extra-low voltage wiring to and from this device is intended to be wired in the field to become part of a Class 1 circuit only.
3. A 1 amp external fuse is suggested on terminal 10 (flame relay common) for over-current protection



NOTICE

When Fireeye products are combined with equipment manufactured by others and/or integrated into systems designed or manufactured by others, the Fireeye warranty, as stated in its General Terms and Conditions of Sale, pertains only to the Fireeye products and not to any other equipment or to the combined system or its overall performance.

WARRANTIES

FIREYE guarantees for *one year from the date of installation or 18 months from date of manufacture* of its products to replace, or, at its option, to repair any product or part thereof (except lamps, electronic tubes and photocells) which is found defective in material or workmanship or which otherwise fails to conform to the description of the product on the face of its sales order. **THE FOREGOING IS IN LIEU OF ALL OTHER WARRANTIES AND FIREYE MAKES NO WARRANTY OF MERCHANTABILITY OR ANY OTHER WARRANTY, EXPRESS OR IMPLIED.** Except as specifically stated in these general terms and conditions of sale, remedies with respect to any product or part number manufactured or sold by Fireeye shall be limited exclusively to the right to replacement or repair as above provided. In no event shall Fireeye be liable for consequential or special damages of any nature that may arise in connection with such product or part.



FIREYE
3 Manchester Road
Derry, New Hampshire 03038 USA
www.fireeye.com

MBCE-1002
MAY 12, 2016
supersedes April 20, 2016