

Operating Manual

HZG53-HEB HZG53-HEB-Zxxxx

Portable High-Energy Handheld Igniter
(Battery-powered)



HZG53-HEB with flexible cable in front of the ignition electrode and short ignition tip ZS-K



HZG53-HEB-Zxxxx with fixed ignition electrode and screwed-on ignition tip ZS-K



The operating instructions must be read carefully before installation, commissioning and maintenance. The instructions must be observed and the operating manual must be kept for later use!

Operating Manual Portable Hand-Held Igniter HZG53-HEB		
Document name	Operating instructions HZG53-HEB_EN	
	Edition of the manual:	First edition: 04/04/2022
		Revision status:
Last update:	06.10.20221	01

The texts and illustrations have been compiled with the utmost care. d.s.f. GmbH (and the authors) cannot assume any legal or any liability for any remaining incorrect or incomplete information and their consequences.

The documentation or parts thereof may not be reproduced, copied or lent or passed on to third parties without the prior written consent of d.s.f. GmbH.

d.s.f. GmbH, as the manufacturer of the portable high-energy hand-held ignition device described, reserves the right to change the equipment and design of the device modules or individual assemblies at any time - even without prior notice. The actual availability results from the individual offer created in each case.

There is no notification when content is changed.

Illustrations may deviate due to the depiction of customer-based special solutions or further developments. No claim to the delivery of identical products can be derived from this.

Safety instructions and protective measures

Safety during operation and operation:

Improper handling can lead to significant personal injury and damage to property. Work on the portable high-energy hand-held ignition device may only be carried out by appropriately trained operating personnel or an electrician.

Operator is a person who is responsible for installing, operating, setting up, maintaining, cleaning, repairing or transporting equipment and machines so that they can recognize and avoid hazards.

A qualified electrician within the meaning of the accident prevention regulation DGUV regulation 3 is someone who, based on their technical training, knowledge and experience as well as knowledge of the relevant regulations, can assess the work assigned to them and recognize possible dangers.

The High Energy Portable Igniter (or any part thereof) is not intended for climbing or standing on.

Electromagnetic interference can occur during the ignition period.

Safety in storage, assembly, installation and maintenance

Proper and safe operation of the device requires proper transport, professional storage, installation and assembly as well as careful operation.

There is a risk of fatal injury when touching live components, so regular visual inspections must be carried out by the user. The visual inspection is limited to the intactness of the connected cables, mechanical connections and the tightness of the screws. Compliance with the permissible ambient temperatures must be checked.

When igniting, 2kV are present at the ignition electrode. There is a risk of death if touched!!!

The portable high-energy hand-held ignition device may only be operated in the combustion chamber with the lid of the ignition unit closed (and with an undamaged cable, depending on the version) and the ignition electrode installed.

A voltage of 2kV is generated in the ignition unit. If damage is found, the ignition system must be taken out of service and sent in for repair. Before inspection work, the power supply must be switched off.

The portable high-energy hand-held ignition device requires at least 120 seconds. After this time you can work on the device.

There is a risk of burns after pulling the ignition electrode out of the combustion chamber. All components such as internal parts and the ignition electrode must be cooled down to ambient temperature before removal. The use of protective gloves and protective work clothing is required.

Protective gloves must be worn when installing the ignition tip. In addition, the risk of crushing when screwing in is pointed out.

Limitations of Liability

The manufacturer accepts no liability for damage due to:

1. Non-compliance with these operating instructions
2. Improper use
3. Use by unqualified or appropriately trained personnel
4. Unauthorized technical and mechanical modifications
5. Use of unapproved replacement parts
6. Use of defective and/or improperly repaired devices or parts
7. Repairs by external companies

Contents

Safety instructions and protective measures	3
Limitations of Liability.....	3
Image directory	4
General	5
Description.....	5
Necessary components for a complete system.....	6
Assembly Instructions:.....	7
Application	9
Loading process	10
Replacing the batteries	11
Technical specifications.....	12
Accessories and spare parts	13
Warranty	14
Disclaimer	14

Image directory

Individual components HZG53-HEB with flexible cable in front of the ignition electrode.....	6
Individual components HZG53-HEB-Zxxxx with fixed ignition electrode	8
Handle top view	9
The ignition start (Ignition)	9
Displays while charging	10
The polarities must be observed when changing the battery	11

General

The operating instructions must be read carefully before commissioning. The device generates a life-threatening voltage of 2kV. Failure to do so may result in personal injury and/or mechanical destruction.

Description

The portable high-energy hand-held ignition device consists of electronics, a 2kV ignition generator and an integrated battery charger. The HZG53-HEB series is used for the safe ignition of gas and light oil burners, e.g. in refineries, the steel industry and in the petrochemical industry. The device is switched ready for operation via a latching switch. The ignition is started with a button.

The device has an LED display that informs the user when the batteries need to be recharged.

Two versions are available:

1. The HZG53-HEB is supplied with a pluggable ignition cable, a junction box and the ignition lance with a replaceable ignition tip. The user can determine the required overall length during the initial assembly by using extension tubes.
2. The HZG53-HEB-Zxxxx version is available with a fixed ignition lance in two different ignition lance lengths. The ignition tips, which can be ordered separately, are interchangeable.

A power cord and carrying strap are supplied with each HZG53-HEB.



WARNING: ATTENTION HIGH VOLTAGE!!!



Before mounting, replacing the ignition tip or opening the ignition unit, it is absolutely necessary to switch off the high-energy ignition unit in order to prevent unintentional ignition.

Due to the discharge time of the capacitors, work on the ignition electrode as well as opening the cover may be carried out at the earliest 120 seconds after the supply voltage has been switched off.

In addition, at least the safety instructions on page 3 must be observed.
The electrical connection may only be carried out by a qualified electrician.

Necessary components for a complete system

Individual components HZG53-HEB with flexible cable in front of the ignition electrode

- HZG53-HEB - Portable high-energy hand-held ignitor with device plug, mains cable and carrying strap
- HZG53-C-1.5 - Ignition cable with handle, ignition tip adapter with high-voltage cable
- ZSH-SSR 0.0 - Ignition tip adapter
- ZS-K / ZS-L - Ignition tip short / long (to be selected depending on the required overall length)
- ZSH-VR.0X - Extension tube (to be selected depending on the required total length)

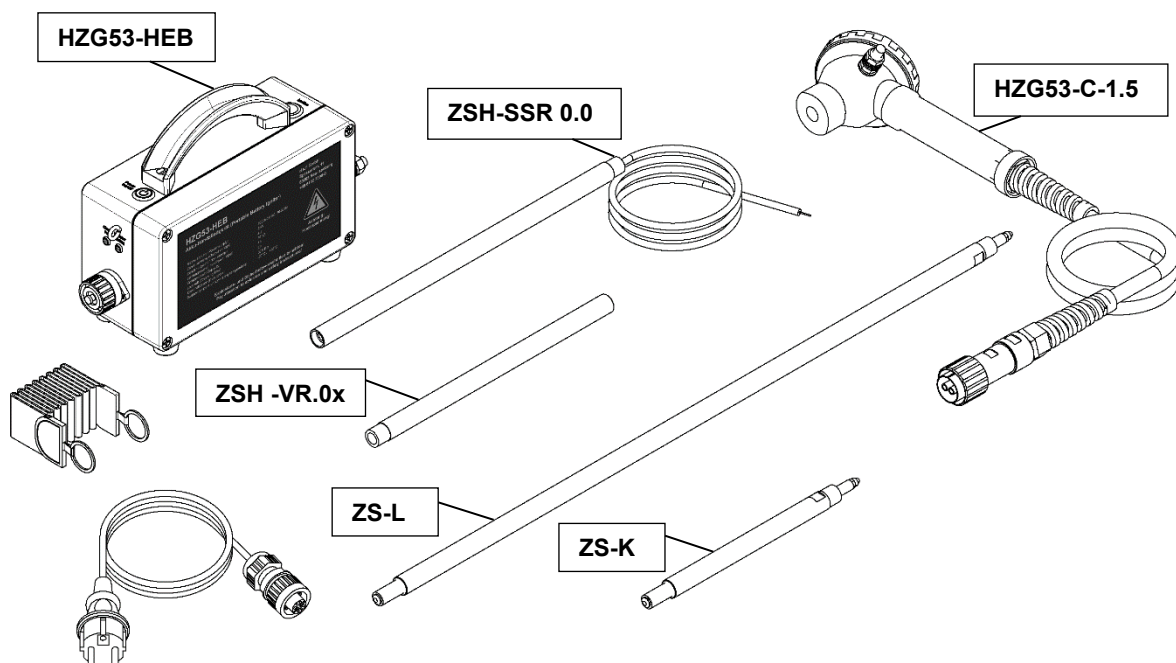

Adjustment of the immersion depth of the ignition electrode above 525mm is made by using optional extension tubes ZSH-VR.XX and selecting ignition tips ZS-K (screwed in 200mm) or ZS-L (screwed in 675mm). Please note that the red high voltage cable is shortened to the required length in the junction box only after all components have been assembled.

A notice:

Due to the pre-assembled high-voltage cable, the electrode length is usually 3 m and can be longer if required. In this case, please contact d.s.f. GmbH.

Assembly Instructions:

If the optionally available extension tubes are used, the extension tube is first screwed into the thread of the junction box. Then the cover of the junction box is unscrewed. The red high-voltage cable from the ignition tip adapter is pulled through the extension tubes into the junction box. The ignition tip adapter is then screwed into the extension tube. If no extension tube is used, the ignition tip adapter is screwed directly into the junction box.

The red high-voltage cable is to be shortened in the junction box so that approximately 8 cm (measured from the bottom of the junction box) remain. The insulation is stripped down to about 1 cm at the ends of the red and brown lines. The wires of the high-voltage cables are inserted into the rotary connector (supplied with the junction box) up to the stop and contacted by turning the connector clockwise.

Before:

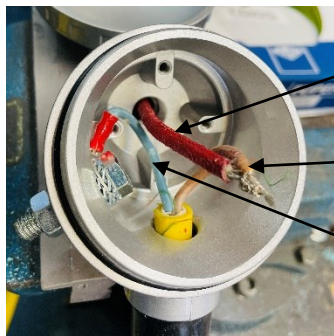

High Voltage Cable (Red)
from the ignition electrode

High voltage cable (brown)
from the ignition unit

Ground connection (blue)
to the ignition unit

After:



The cover of the junction box is screwed on again in the last step.

The ignition tip ZS-K or ZS-L has to be screwed into the ignition tip adapter.

For personal protection and for later use, it is recommended to connect a protective conductor (minimum cross-section 4mm²) to the external PE connection bolt of the junction box with a grounding clamp for connecting the ground potential to the burner (see installation instructions described below).

Protective conductor assembly

The insulation of the PE wire must be offset by approx. 8mm at the end. The supplied yellow ring cable lug (4 mm²) is fitted here with crimping pliers (model for insulated ferrules with forced lock). The yellow ferrule is placed on the external grounding bolt on the housing and secured with the washer and serrated lock washer and a nut.

On the other side of the PE cable, a grounding clamp should be connected to metal surfaces grounded on the system side for easy handling to ensure good contact.

A ready-made PE cable with mounted grounding clip is available as an accessory (HZG53-Pot).

Individual components HZG53-HEB-Zxxxx with fixed ignition electrode

- HZG53-HEB-Zxxxx - Portable high-energy hand-held ignitor with mains cable and carrying strap
 ZS-K / ZS-L - Ignition tip short / long (to be selected depending on the required overall length)

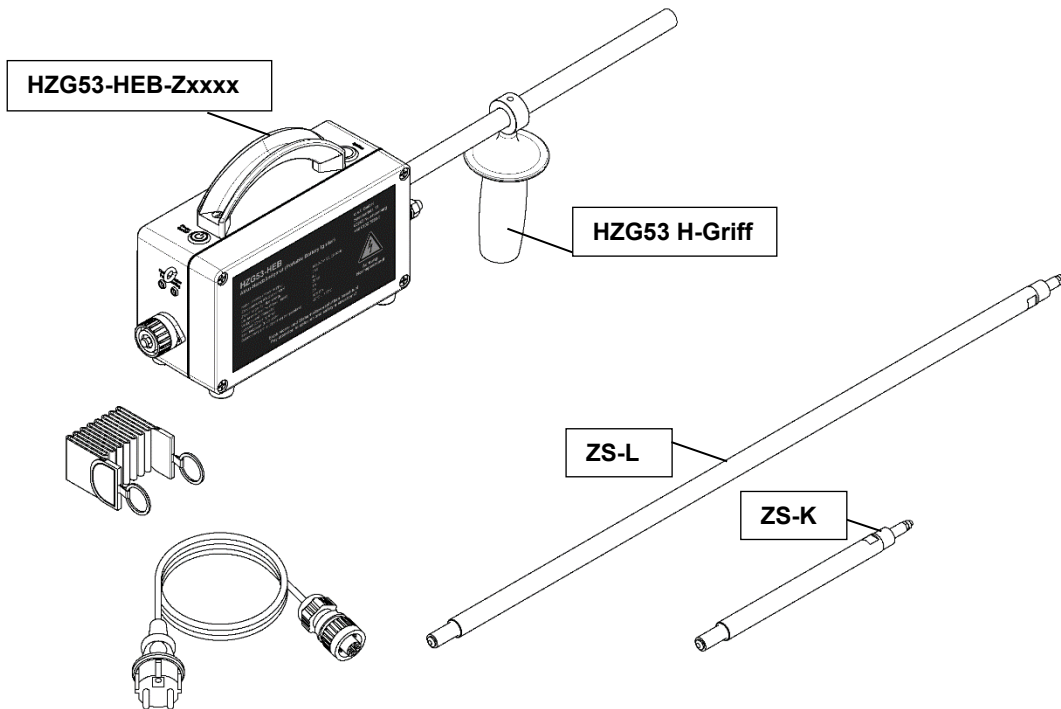

(Representation with optionally available grab handle HZG53 H-GRIFF)

The ignition unit is already pre-assembled. Only the ignition tip ZS-K or ZS-L has to be screwed in.

For personal protection and for later use, it is recommended to connect a protective conductor (minimum cross-section 4mm²) to the external PE connection bolt of the junction box with a grounding clamp for connecting the ground potential to the burner (see installation instructions described below).

Protective conductor assembly

The insulation of the PE wire must be offset by approx. 8mm at the end. The supplied yellow ring cable lug (4 mm²) is fitted here with crimping pliers (model for insulated ferrules with forced lock). The yellow ferrule is placed on the external grounding bolt on the housing and secured with the washer and serrated lock washer and a nut.

On the other side of the PE cable, a grounding clamp should be connected to metal surfaces grounded on the system side for easy handling to ensure good contact.

A ready-made PE cable with mounted grounding clip is available as an accessory (HZG53-Pot).

Application

Caution! Hot surface possible!



Danger of burns: The ignition electrode may be hot after being pulled out of the combustion chamber and also after ignition has taken place - it is essential to wear protective gloves!

Before commissioning, potential equalization should be carried out between the grounding bolt on the housing and the front panel of the burner, for example with the optionally available potential equalization line (at least 4 mm² PE cable with grounding clamp, length 3m).

Handle top view

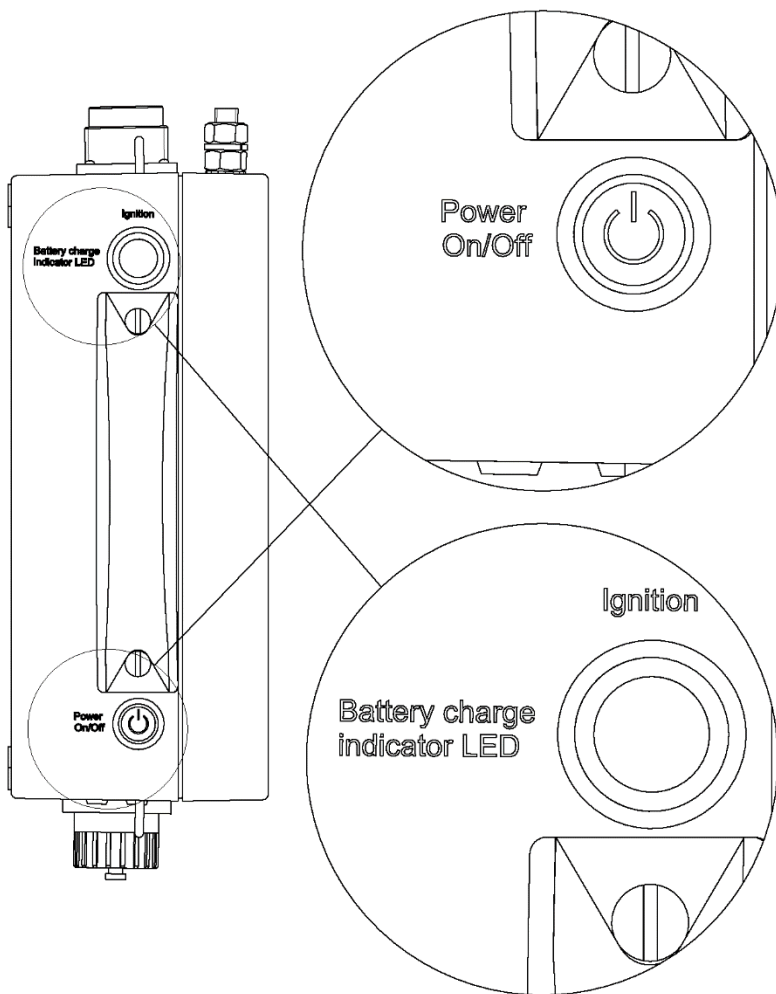

Switching the device on and off (Power On/Off)

The device is switched on and ready for operation by pressing the latching switch on the top of the device.

In the On state, the background LED lights up in white.

Push the electrode of the portable ignition device into the combustion chamber.

The ignition start (Ignition)

To ignite, the " Ignition " button (in front of the handle on the side of the ignition lance) must be pressed.

If the ring light turns red (Battery charge indicator LED), the battery level is too low and the batteries must be recharged.

Once the mixture has ignited, stop pressing the button to stop the ignition. After withdrawing the ignition electrode from the combustion chamber, press the white-framed Power On/Off switch on the top of the device again to shut down the device.

Attention!

The device is not suitable for continuous ignition!

Loading process

ATTENTION!!!

Before each charging process, the connection cable and the plug connection must be checked for damage. A defective charging cable must not be used and must be replaced. If any damage is detected, the device must be sent to the manufacturer for repair.

The rechargeable battery (three individual cells) of the hand-held ignition device is charged via the supplied mains cable. Ignition is not possible during the charging process. Depending on the state of charge of the battery, this process can take up to 2 hours. After charging, the hand-held ignition device must be disconnected from the mains.

If the ignition spark is very weak and the red background LED on the ignition button lights up, the battery should also be charged.

Displays while charging

The charge status displays are located on the back of the hand-held ignition device.

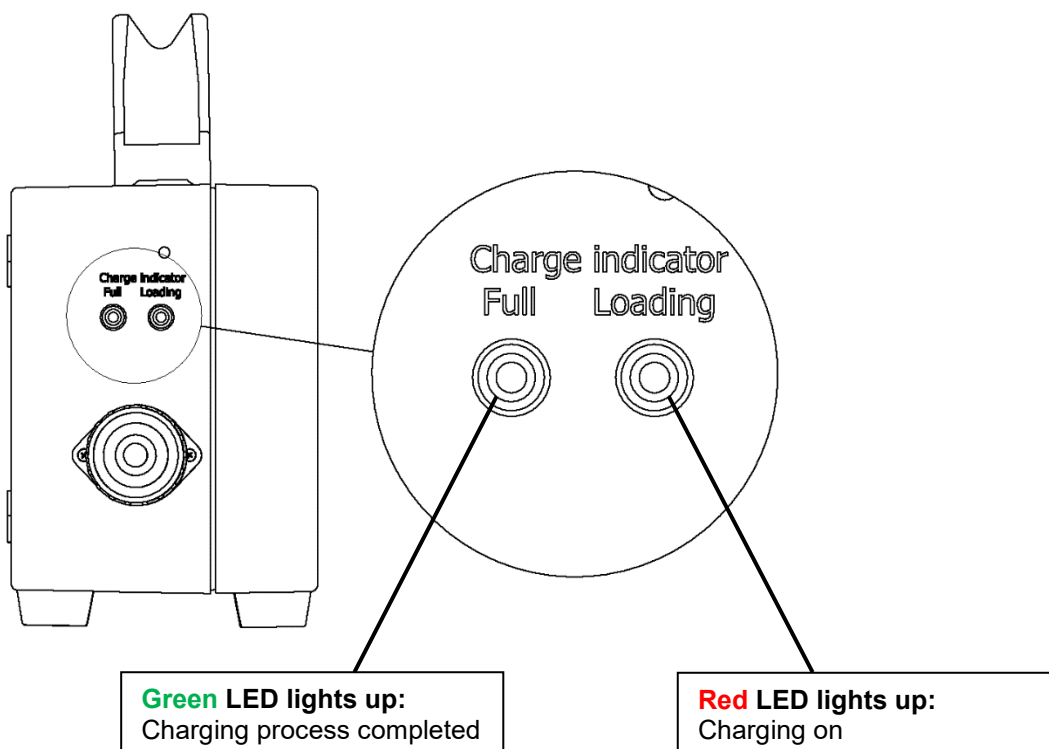

When not in use, the device must be disconnected from the mains after the charging process has been completed. To ensure full battery capacity, we recommend recharging the hand-held ignitor at intervals of approx. two months and then disconnecting it from the mains again.

Replacing the batteries

The battery can only be replaced by a qualified electrician.



WARNING: HIGH VOLTAGE!!!



Before opening the ignition unit, it is absolutely necessary to disconnect the mains connection and secure it against being switched on again. It must be checked whether the operating switch is switched off. (background LED off).

Due to the discharge time of the capacitors, both work on the ignition electrode or opening the cover of the ignition unit may be carried out at the earliest 120 seconds after the supply voltage has been switched off and the unit has been switched off (Power Off).

The housing cover can be opened by loosening the four screws (on the side of the type plate). Beware of live parts! It must be ensured that the PE connection between the two housing parts is not interrupted.



The polarities must be observed when changing the battery

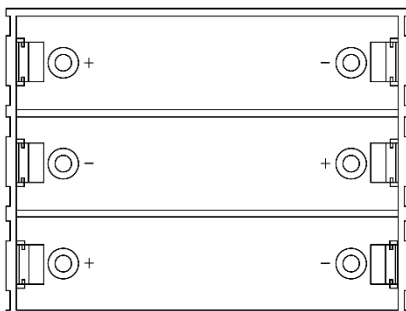

To avoid compensating currents, all batteries must always be replaced at the same time. When installing the housing cover, make sure that the PE connection between the housing parts is not pinched. After replacing the batteries, the housing cover must be attached again with the four previously loosened screws.

Proper operation can only be guaranteed with the batteries installed by the manufacturer.

Technical specifications

Ignition Voltage:	2kV
Ignition frequency:	3 sparks/sec
Ignition energy:	4 J / spark
Maximum ignition duration:	180 s (ED 30%)
Max. current consumption during charging:	1.0 A
Supply voltage: (For charging the batteries)	100 - 240 V, 50/60 Hz
Operational availability:	approx. 1 hour
Charging time:	approx. 2 hours
Protection class of the housing:	IP 54
Permissible operating temperatures: Control unit: Ignition electrode (tip):	- 20 °C to + 65 °C + 650 °C, briefly up to + 800 °C
Dimensions basic device (L x W x H): HZG53-HEB: HZG53-HEB-Zxxxx:	280 x 90 x 180 mm 605 x 90 x 180 mm
Housing material:	Die-cast aluminum, powder-coated
Weight basic device: HZG53-HEB (remote ignition electrode) HZG53-HEB-Zxxxx (fixed ignition electrode)	approx. 2.7 kg (varies depending on length) approx. 3.1 kg (varies depending on length)
Possible ignition electrode total lengths	
HZG53-HEB (Length without firing tip):	325 mm
Total insertion depth through use of extension tubes:	
525mm	with ZS-K (200 mm)
725 mm	with ZSH-VR.02 (200 mm) and ZS-K (200 mm)
825 mm	with ZSH-VR.03 (300 mm) and ZS-K (200 mm)
925 mm	with ZSH-VR.04 (400 mm) and ZS-K (200 mm)
1000 mm	with ZS-L (675mm)
1125 mm	with ZSH-VR.06 (600 mm) and ZS-K (200 mm)
1225 mm	with ZSH-VR.07 (700 mm) and ZS-K (200 mm)
1325 mm	with ZSH-VR.08 (800 mm) and ZS-K (200 mm)
1400 mm	with ZSH-VR.04 (400 mm) and ZS-L (675 mm)
1500 mm	with ZSH-VR.05 (500 mm) and ZS-L (675 mm)
HZG53-HEB-Zxxxx:	xxxx is a placeholder for the total electrode length 0725 for 725 mm with ZS-K 1000 for 1000mm with ZS-L
Ignition electrode diameter:	16 mm

Accessories and spare parts

- Order no.: DISTANZRING ZÜND 16
Spacer ring with 16.5mm inner diameter and Allen screw for locking

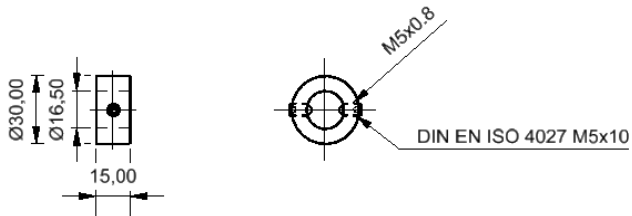

- Order no.: HZG53 H-GRIFF
grab handle

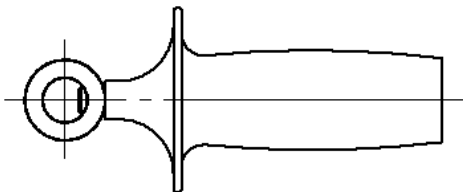

- Order no.: HZG-AKKU SET
The set consists of three flat-top Li-Ion single batteries 3.7V, 3000 mAh .

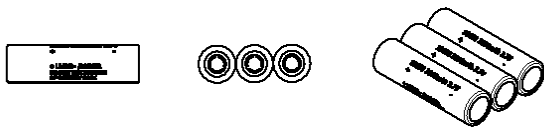

- Order No.: ZS-K
Replacement ignition tip, screwed in 200 mm long

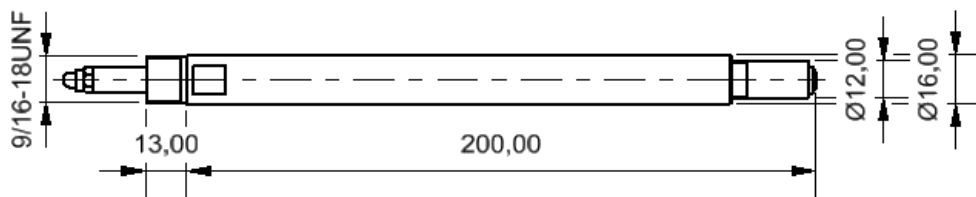

- Order No.: ZS-L
Replacement ignition tip, screwed in 675 mm long

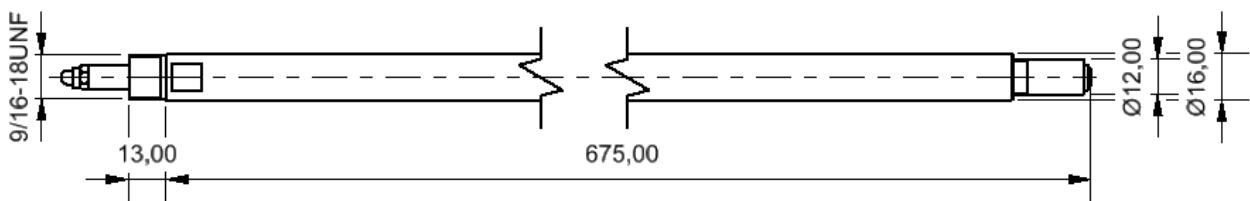

- Order No.: ZSH-VR.0x
Extension tube (see technical data for selection of different lengths)

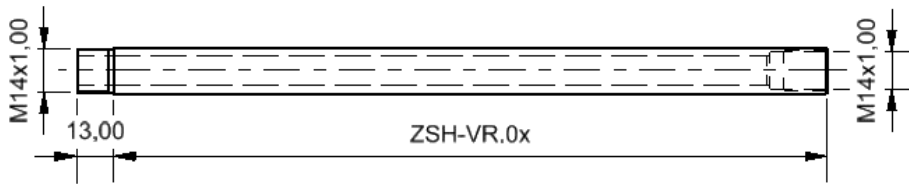

- Order no.: HZG53-Pot
PE - compensation line

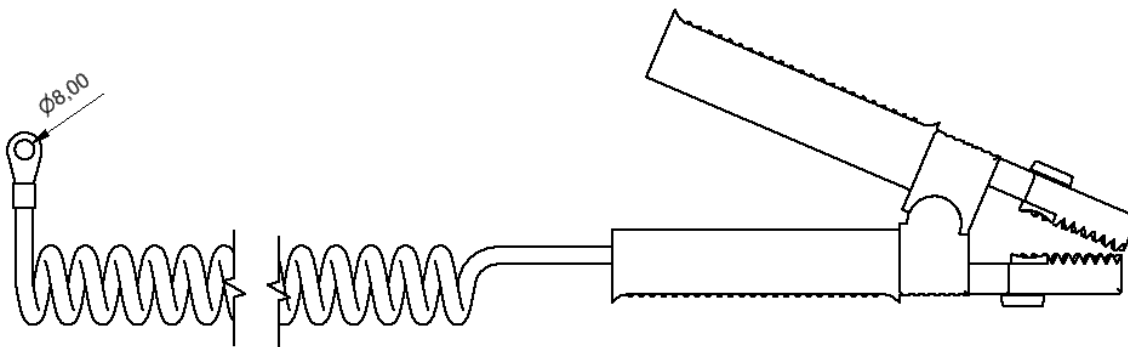

Warranty

From the date of delivery, we guarantee for a period of 24 months to eliminate any errors that may occur or to replace the device. The prerequisite for this is that an error that has occurred can be traced back to defects in components or to incorrect assembly of components.

The product warranty is void if modifications are made to the device by the user himself or by third parties that have not been expressly approved in writing by d.s.f. GmbH.

Repairs are only carried out in our workshop.

A reimbursement of costs for repairs by other workshops is excluded.

The customer bears the costs for sending a defective device to d.s.f. GmbH.

Please note!

A warranty is excluded for wearing parts such as the accumulator and the ignition tips ZS-K and ZS-L, since the service life depends on the number of ignitions, charging processes and the conditions of use.

Disclaimer

d.s.f. GmbH does not assume any liability for consequential damage caused by a defect in a device. d.s.f. GmbH cannot be held liable in any way for any claims arising from non-compliance with these instructions for use.

d.s.f GmbH
Spessartstraße 11
D - 63263 Neu-Isenburg
Telefon +49 6102 / 7890-0
Telefax +49 6102 / 7890-40
E-mail: info@dsf-gmbh.de
www.dsf-gmbh.de